

BESI Installation Instructions

Installing Safe Journey Seat Mount

1. Lift the cushion portion of the bench seat, and place the male end of the cam wrap buckle into the space between the seat cushion and the seat back (also known as the “seat bight”). Close and secure the seat cushion assembly. On some seats, lifting the seat cushion is unnecessary; simply push the male end of the seat mount through the seat bight, between the cushion and back until it is visible from behind and below the seat.
2. Place the female end of the seat mount buckle over the top of the seat back and bring the male end around from the bottom. Click belt buckle together making sure that release button is facing inward toward the seat back. Buckle should be positioned low, near the middle to bottom of the seat back (see Fig. 2).
3. Extend the bottom pelvic hooks about 1 to 3 inches out of the seat bight onto the seat cushion. Let the shoulder straps hang temporarily.
4. The slide adjuster can be used to fit the belt around the seat back.

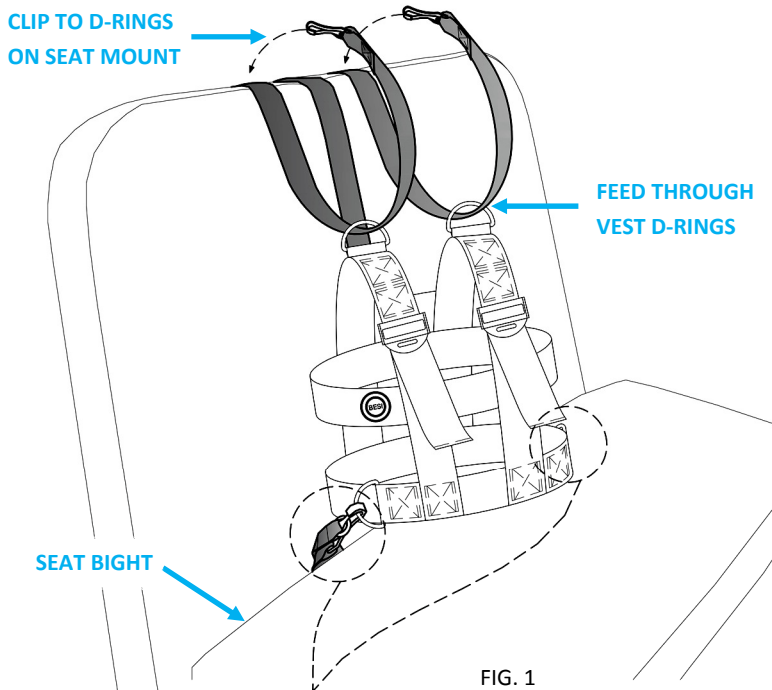

Attaching Vest to Safe Journey Seat Mount

1. With passenger sitting down, feed the long shoulder straps through the upper D-rings of the vest and circle around to fasten to D-rings on seat mount behind the seat (see Fig. 1). If straps are loose, tighten until snug by using roller adjusters on the seat back (see Fig. 2). If there is not enough room to tighten the shoulder straps using the roller adjusters, the upper yoke of the seat mount will need to be raised or lowered using the slide adjuster.
2. Ensuring the passenger is seated snugly against the seat bottom and seat back, clip snap hooks onto lower D-rings at the hips as shown in Fig. 4. Pull D-ring far back into the curve of the hook to make room for the O-ring.
3. Cock snap hook webbing at an angle (fold the snap hook against its webbing) and slip metal O-ring over snap hook tongue (see Fig. 5).
4. Once both the D-ring and O-ring are secured in the snap hook, ensure hip straps are pulled snug into the seat bight. As long as the straps are pulled tight, the passenger will find difficulty in removing the snap hook with the O-ring in place.
5. To remove the lower snap hooks, reverse the above process. Tip: Ensuring the D-ring is square/parallel with the snap hook and not skewed will aid in removing the O-ring.
6. To remove the upper shoulder straps, lift the roller adjusters to loosen the webbing until it can be easily unclipped from the D-ring.

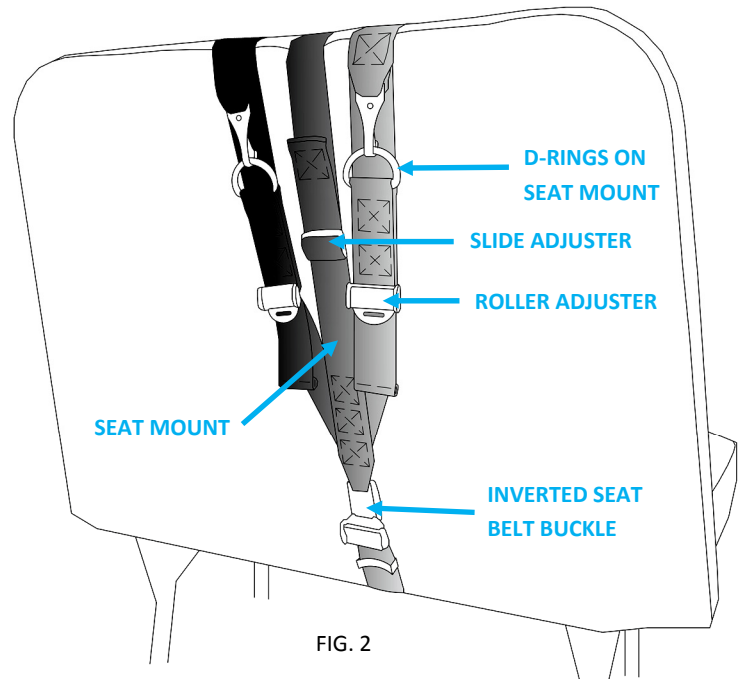

ENSURE O-RING IS CLEAR FROM SNAP HOOK

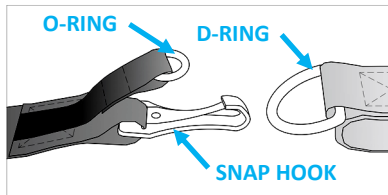

CLIP SNAP HOOK TO D-RING

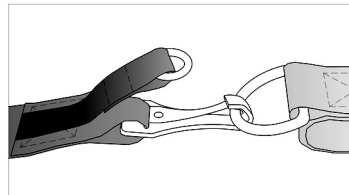

ANGLE WEBBING AND SLIP ON O-RING

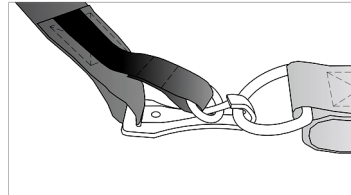

PULL UNTIL TAUGHT

